

# WERTSCHÖPFUNG DURCH IP

Dr. Christian Köster

Patentanwalt

Chemiker

21.05.2025

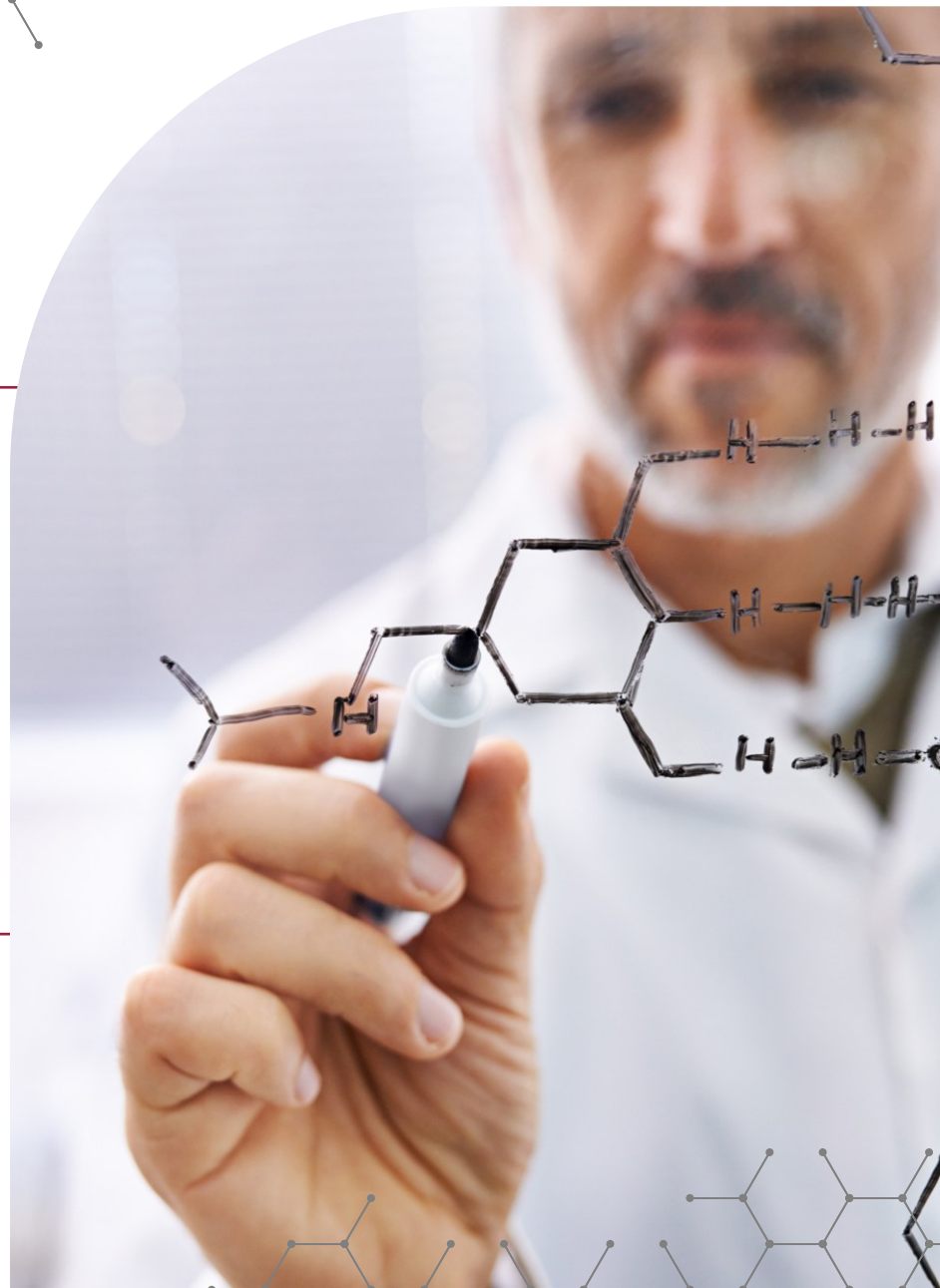

# DESIGNS (I)

**United States Patent** [19]  
**McQuarrie et al.**

[11] **Des. 251,628**  
[45] **Apr. 17, 1979**

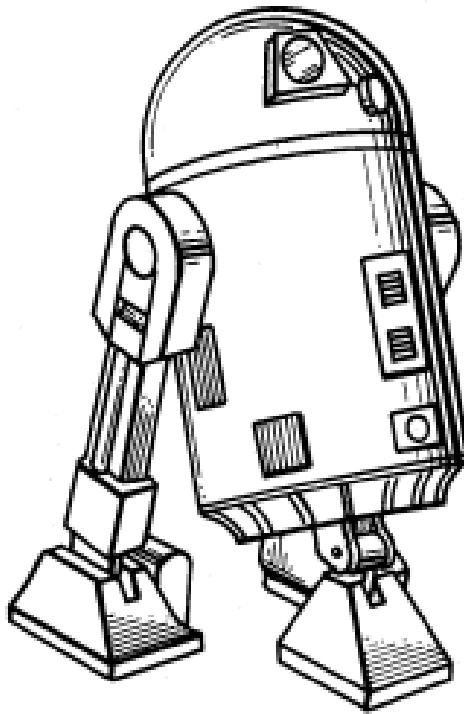



# DESIGNS (2)

## Star Wars Schutzrechtsstrategie

---

- Design-Schutzrechte auf X-Wing, Yoda, etc.
- Schutzrechtsdauer: 25 Jahre
- Merchandising-Umsatz bis 2018: 70 Milliarden Dollar  
(Schätzung; Quelle: DPMA)

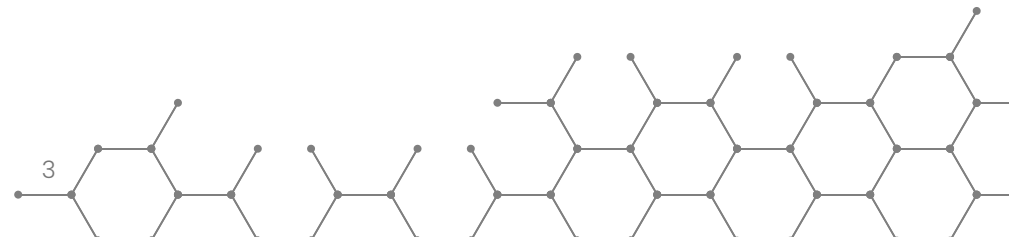

# DESIGNS (3)



COURT OF JUSTICE  
OF THE EUROPEAN UNION

**PRESS RELEASE No 15/24**

Luxembourg, 24 January 2024



**Intellectual property: the General Court of the European Union upholds the validity of the protection of the Lego toy brick**

# DESIGNS (4)

## DESIGNview

Weltweite Suche in  
EU-Datenbank

 [Name des Inhabers: \*\*LEGO A/S\*\*](#)

  
Export

  
Vergleichen

  
Benachrichtigungen

  
Tags (Kennzeichnungen)

«« 1-20 Aus 7.256 »»



Umfangreiches  
Portfolio

# MARKEN (I)



# MARKEN (2)

## Das vielseitige Schutzrecht

- Wortmarke, z.B. „*May the force be with you*“
- Bildmarken, z.B. 
- Farbmarken, z.B. Lila, Gelb, Magenta
- 3D-Marken, z.B. 
- Entscheidend: Unterscheidungskraft

# MARKEN (3)

## Das ewige Schutzrecht

- Schutzrechtsdauer: 10 Jahre
- Immer um weitere 10 Jahre verlängerbar
- Beispiel: Marke von 1989:



**Red Bull**

# MARKEN (4)

## Das mächtige Schutzrecht (i)

- ID.6: in und nur für China gebauter SUV
- Händler importiert 22 Fahrzeuge
- Angestrebter Verkaufspreis EUR 39.000



# MARKEN (5)

## Das mächtige Schutzrecht (ii)

- VW hält Marke „ID.6“
- Beschlagnahme per eV (LG und OLG Hamburg)
- Vernichtungsanspruch geltend gemacht

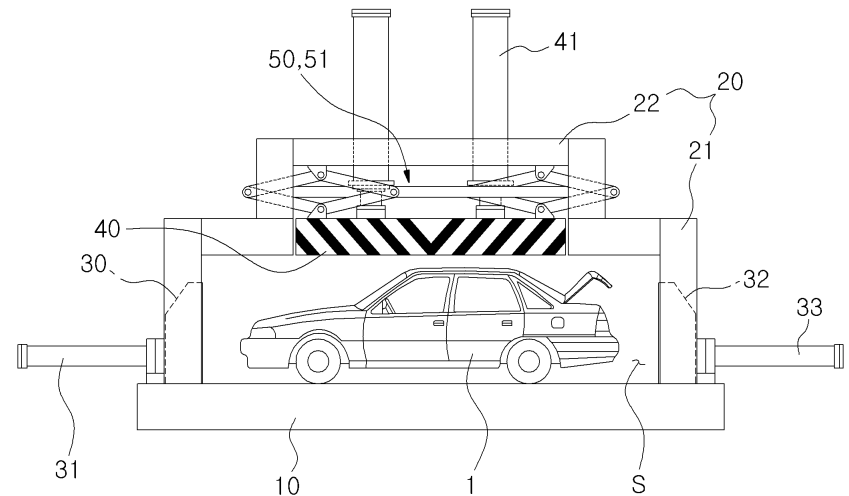

# PATENTE (I)

Technik + Recht = Scharfes Schwert

Unterlassung



Schadensersatz

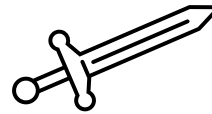

Vernichtung

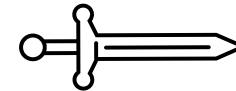
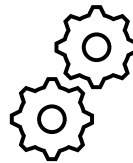
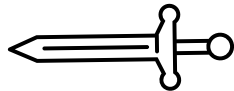

Auskunft

Veröffentlichung

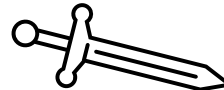
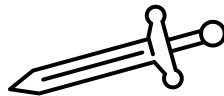

Saisie contrefaçon

# PATENTE (2)

## Wert (Beispiel)

- Bsp.: Google kauft Motorola einsch. 17.000 Patenten
- Behördlich angezeigter Wert: 5,5 Milliarden USD
- Mittelwert: 323.529 USD
- Streitwert in Verletzungsverfahren: mind. 250.000 EUR
- BGH: Patentwert = Streitwert + 25% = 312.500 EUR



# PATENTE (3)

## Wertbestimmung

- Neu: seit 2023 einheitliches Europäisches Patent
- Marktmethode – ggf. zu wenig Vergleichsdaten
- Kostenmethode – unterschlägt erlangte Rechtsposition
- Ertragsmethode – ggf. keine Erträge bestimmbar
- Andere Methoden, z.B. PatentPentagon®

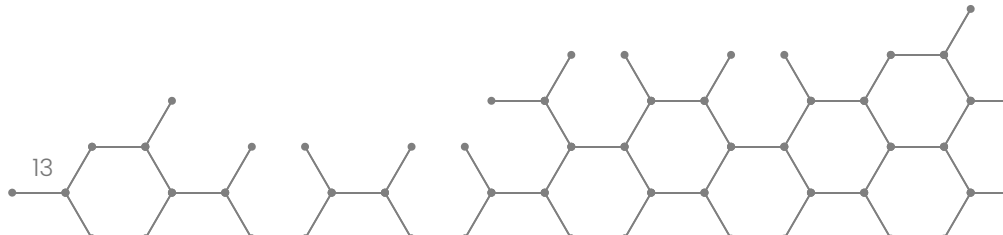

# PATENTE (4)

## PatentPentagon®

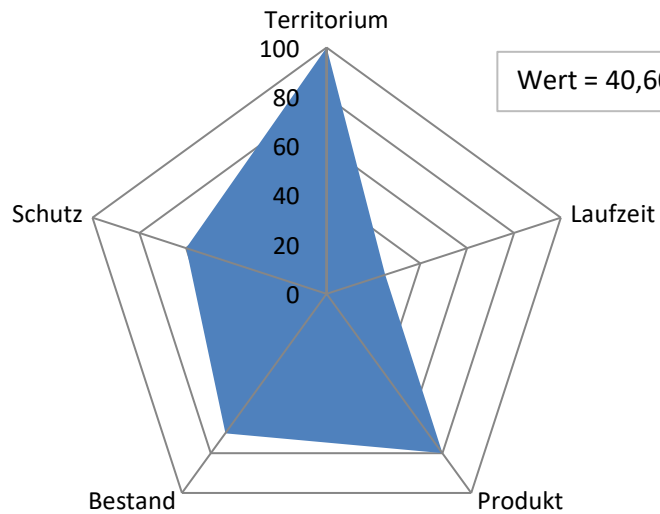

Wert = 40,60%

100% = 312.500 EUR

40,6% = 126.875 EUR

# PATENTE (5)

## Brückenbauer in M&A

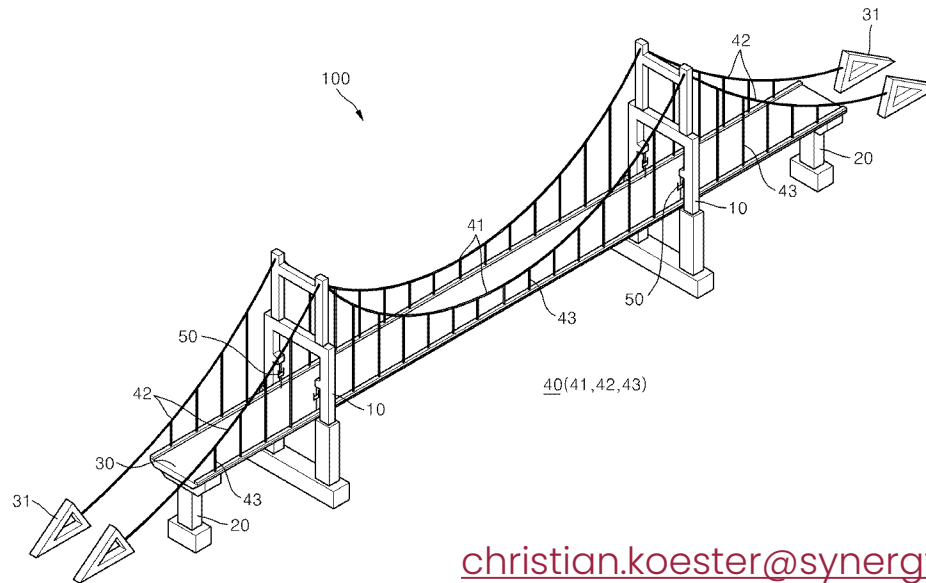

[christian.koester@synergyipgroup.com](mailto:christian.koester@synergyipgroup.com)

